

# VXT/TOF/2M-BP

## Laser Photoelectric Diffused Sensor (TOF)

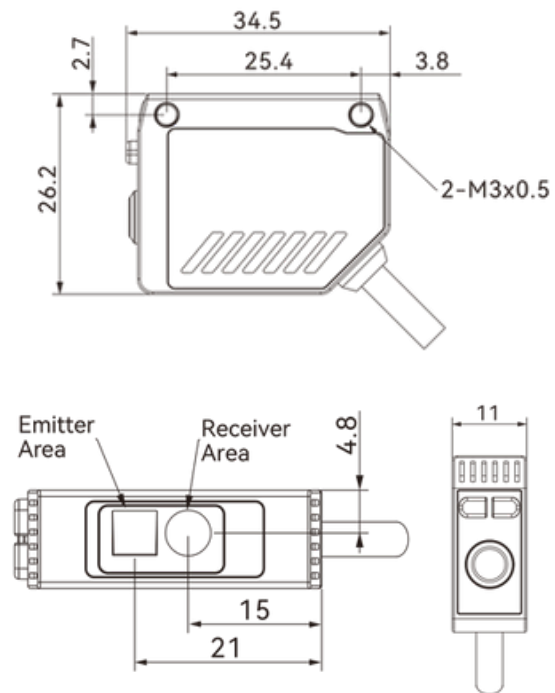

<b>Working principle</b>	TOF principle
<b>Housing style</b>	Square
<b>Optical working principle</b>	TOF (Time of Flight)
<b>Detection Range</b>	0.05~2m
<b>Spot Size</b>	<5mm@2m
<b>Detected Object</b>	≥φ5mm opaque object
<b>Light Source</b>	Laser diode 650nm, Class 2

## Technical data

Indicator light	Output Indicator Light: Orange Power Indicator Light: Green
Sensitivity Adjustment	Button setting
Switch Mode	NC/NO switchable
Output Mode	PNP open collector
Response Time	1ms
Switching frequency	<10mm
Repeatability	<20%
Operating Voltage	9~30V DC
Current consumption	<30mA@24V
Residual Voltage	<1V(Load current<100mA
Load Current	≤100mA
Insulation Resistance	≥50MΩ(500VDC)
Withstand Voltage	1000VAC (50/60Hz)
Protecti On Circuit	Reverse polarity protection/short circuit protection
Operating temperature	-20°C~+55°C(No Freezing)
Operating humidity	35%~85%RH(No Condensation)
Ambient light Vibration	Incandescent Lamp ≤ 3000 Lux; Sunlight ≤ 10000 Lux
Resistance Maximum	10~55Hz, amplitude 1.5mm, 2 hours each in X/Y/Z axes
Tightening Torque	IP54
Maximum Tightening Torque	0.5N·m
Connection Method	Φ4.0*2M/3 Black cable
Dimensions	34.5*26.2*11mm
Weight	0.05kg

# Connecting Diagram (PNP-Output)

PNP Output

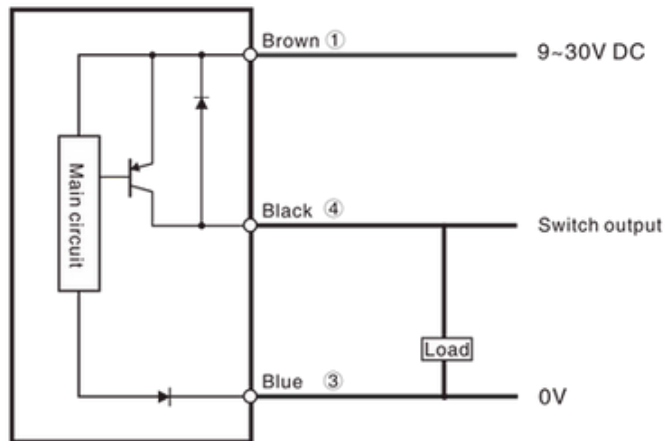

1. Please connect the sensor as per above wiring diagram .
2. If the wires are not connected as per connection diagram shown above, the sensor may get defective or not work

**VoxinTech**

**Email:** [info@voxintech.com](mailto:info@voxintech.com)

**Website:** [www.voxintech.com](http://www.voxintech.com)