

# PE18P/D40-45A-R

## Photoelectric Sensor (Diffuse Reflection)

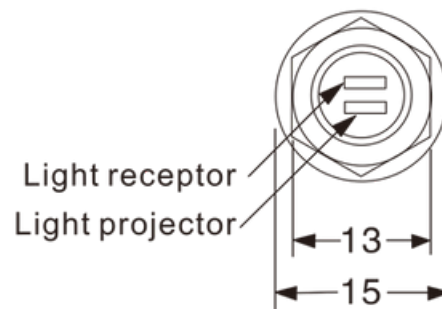
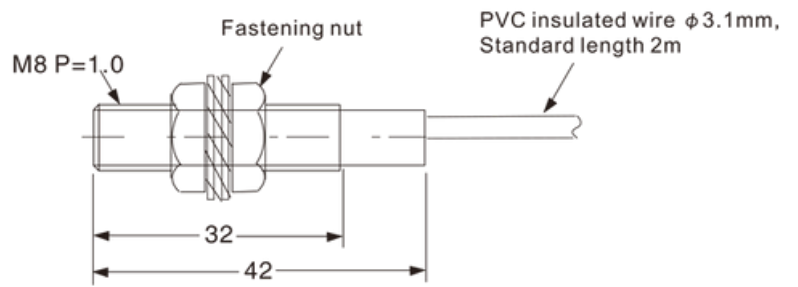

<b>Working principle</b>	Photoelectric sensor
<b>Housing style</b>	Cylinder Shape
<b>Optical working principle</b>	Diffuse reflection
<b>Detection Range</b>	100~400mm
<b>Detected Object</b>	7mm
<b>Spot Size</b>	Ø 36.0 mm / 0.40 m
<b>Light Source</b>	Red LED

## Technical data

Indicator light	Power status: Green LED, running status: red LED
Sensitivity Adjustment	1 turn potentiometer
Switch Mode	L.on (light entry action) /D.on (light blocking action) can be switched
Output Mode	PNP open collector
Response Time	2ms
Switching frequency	1kHz
Repeatability	5%
Hysteresis	≤20%
Operating Voltage	10~30V DC
Current consumed	≤25mA
Residual Voltage	≤1.5V (120mA)
Insulation Resistance	≥50MΩ(500VDC)between power terminal and housing
Load Current	≤120mA (30VDC)
ProtectiOn Circuit	Reversepolarityprotection/short circuit protection
Operating humidity	30~90%RH (no condensation)
Storage humidity	35 to 95%RH (no condensation)
Ambient light	Incandescentlamp ≤3000 Lux; Sunlight exposure ≤ 10,000 Lux; LED lights ≤3000Lux
Vibration Resistance	10~50Hz, 0.5mmamplitude, 2 hours in each direction X, Y and Z
Protection rating	IP67
Maximum Tightening Torque	0.5Nm
Connection Method	2M/ 4-core cable
Dimensions	M18X43.5 mm
Weight	0.05 kg
Material	PC
Accessories	Nut M18x1

# Connecting Diagram (PNP-Output)

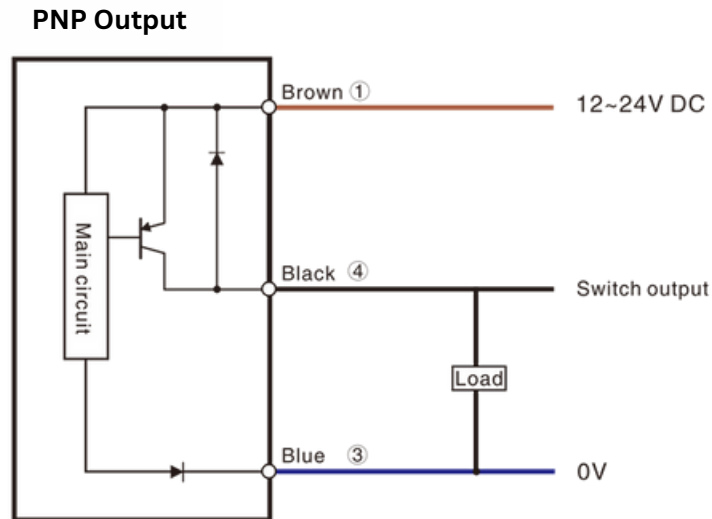

1. Please connect the sensor as per above wiring diagram .
2. If the wires are not connected as per connection diagram shown above, the sensor may get defective or not work

**VoxinTech**

**Email:** [info@voxintech.com](mailto:info@voxintech.com)

**Website:** [www.voxintech.com](http://www.voxintech.com)