

VTIN/1204P-FA50

Inductive Sensor

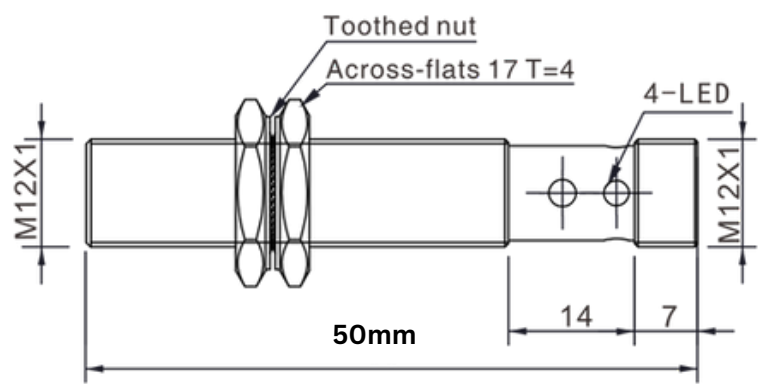

Working principle	Inductive sensor
Housing style	Cylindrical
Installation type	Flush
Sensing distance	4.0mm±10%
Thread Size	M12
Sensing Surface Material	PBT
Detected objects	Metal Sensor

Technical Data

Indicator	Operating status: LED
Sensing range adjustment	None
Switching output	Normally open
Output Mode	PNP
External input	None
Switching frequency	0.3 kHz
Repeatability	5%
Hysteresis	15% or less
Operating Voltage	10~30V DC±10%
Current Consumption	≤10mA
Residual Voltage	2.0 V or less
Load Current	150mA
Leakage Current	< 0.01 mA
Insulation Resistance	≥50MΩ (500VDC) between power terminal and housing
Dielectric strength	1000VAC (50/60Hz), 1 minute between the power terminal and housing
Vibration Resistance	10 to 55Hz, amplitude 1.5mm, X/Y/Z axis, 2 hours each
Circuit Protection	Short circuit protection
Operating temperature	-25~+75°C
Protection rating	IP67
Dimensions	M12x49.7mm
Material	Nickel-copper alloy +PBT
Weight	0.05kg
Connection type	2m/3 wire cable
Operating humidity	35~85%

Connecting Diagram (PNP-Output)

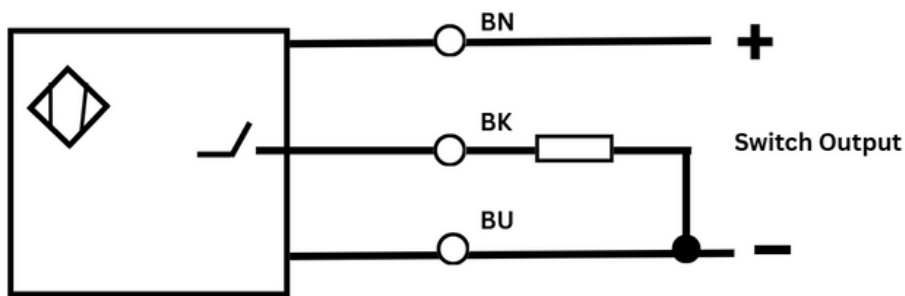

1. Please connect the sensor as per above wiring diagram .
2. If the wires are not connected as per connection diagram shown above, the sensor may get defective or not work

VoxinTech

Email: info@voxintech.com

Website: www.voxintech.com