

## Detection properties

Nominal sensing distance	400mm
Thermal drift of Sr	±2%
Repeat Accuracy	0,50%
Beam angle	10° ± 2°
Resolution	≤3mm
Sensitivity adjustment	Teach-in button
Hysteresis	1%
thermal compensation	Yes
Minimum sensing distance (blind zone)	50mm
Linearity error	1%

## Application

Function Principle

Diffuse reflection

## Outputs

Output type	PNP + 0...10V
Output Function	NO/NC + positive/negative slope
Switching frequency	10Hz

Response time	500ms
---------------	-------

## Electrical data

Operating Voltage	10 - 30Vdc
No-Load supply current	≤50mA
Load current	100mA
Leakage current	10µA @ 30Vcc
Output voltage drop	2,2Vmax. @ IL=100 mA
Max ripple content	5%
LED indicators	green: echo - yellow: output
Time delay before availability	≤300ms
Short-circuit protection	Yes
Reverse Polarity Protection	Yes
Impulsive Overvoltage Protection	Yes
Minimum load resistance	3kΩ

## Mechanical data

Dimensions	M18 x 1 / L = 83,6mm
Weight	170g
Housing Material	stainless steel AISI 316L
Connections	2m PVC Cable
Tightening torque	50Nm
Operating temperature	- 20°C...+ 70°C
Storage temperature	- 35°C...+ 80° C without freeze
Transducer Frequency	300kHz
Diameter/Dimension	M18

## Test/Approvals

Approvals	CE cULus
EMC compatibility	IEC 60947-5-2
Shocks and vibrations	IEC EN60947-5-2 / 7.4
Degree of protection	IP67

## Accessories

Supplied Accessories	2 nuts M18x1, 2 washers Ø 18
----------------------	------------------------------

# ELECTRICAL DIAGRAMS OF THE CONNECTIONS

---

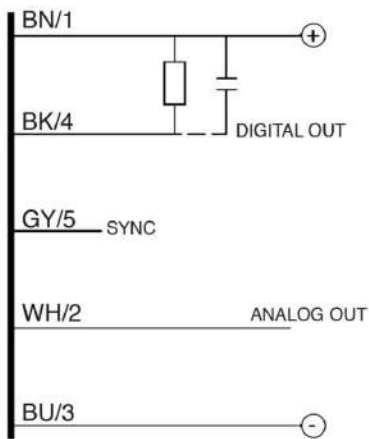

## CONNECTOR

---

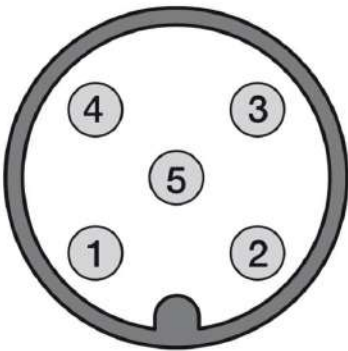

## RESPONSE CURVES

---

### Disassamento Parallelo

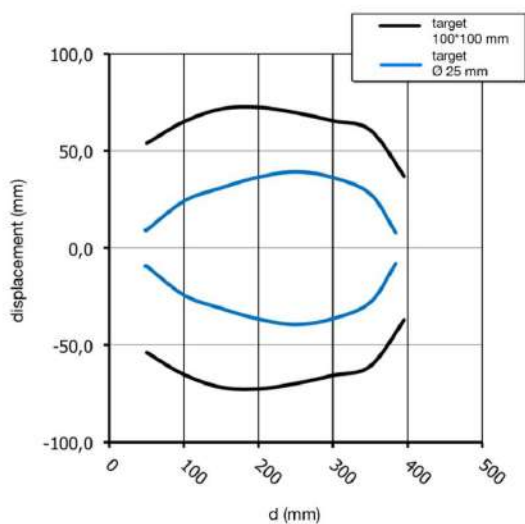

**VoxinTech**

Email: [info@voxintech.com](mailto:info@voxintech.com)

Web: [www.voxintech.com](http://www.voxintech.com)